

Meter Pits

Model	Description	Weight
2-Piece	2Pc; 28" od/24" id 36" + 12" = 48"	860
3-Piece	3Pc; 28" od/24" id 24" + 12" + 12" = 48"	860
4-Piece	4Pc; 28" od/24" id 12"+12"+12"+12"	860
Tapered Ring	Reducer; 24" to 20"	150

* We can carry 24 meter pits on our truck for delivery

All meter pits are 2" thick, fully reinforced,
5,000 PSI mix design, wet-cast concrete

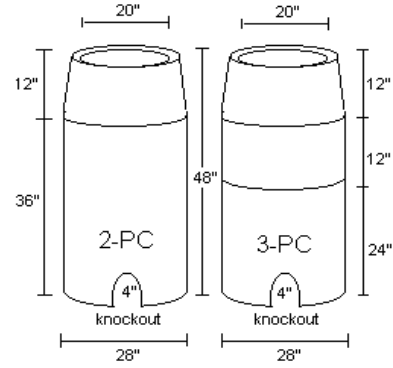
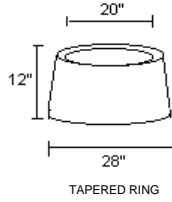

24" Riser Rings (28" OD/24" ID)

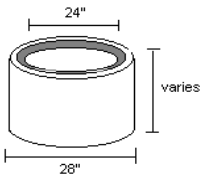

Model	Height	Weight
24x 3 riser ring	3"	45
24x 4 riser ring	4"	60
24x 6 riser ring	6"	90
24x 12 riser ring	12"	180
24x 24 riser ring	24"	360
24" Lid	NA	45

All riser rings are 2" thick and have a lip so they can be nested one inside the other for varying heights

20" Riser Rings (24" OD/20" ID)

Model	Height	Weight
20x 2 riser ring	2"	30
20x 3 riser ring	3"	30
20x 4 riser ring	4"	40
20x 6 riser ring	6"	60
20x12 riser ring	12"	120
20" Lid	NA	30

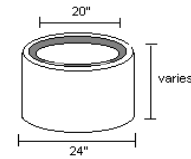

Open Ditch Liners

Width	Length	Depth	Weight
16"	4'	8"	
18"	8'	8"	
40"	8'	18"	
42"	8'	18"	2100

Grate covers available based on individual bids

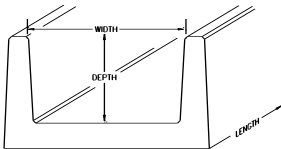

Feed Bunks

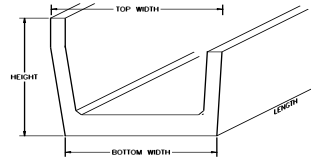

Model	Height	Bottom	Weight
8' Feed Bunk	27"	31"	2100
Two End Plates			
Legs			

RETAINING WALLS

Standard Wall Unit

Height	Length	Depth	Weight
3'	6'	24"	1200
4'	8'	27"	2380
6'	6'	36"	3100

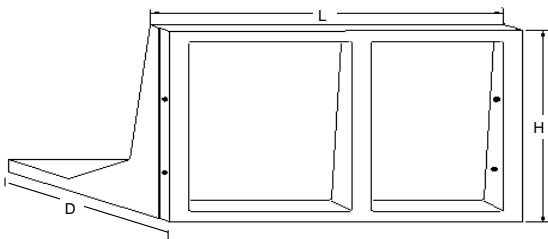

T-Wall Unit**

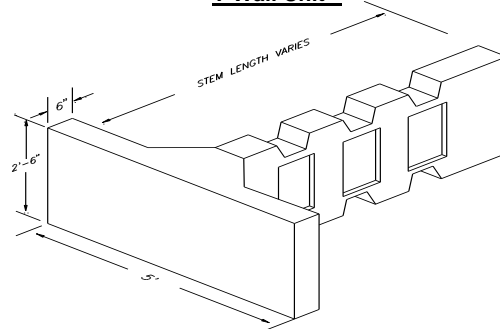

** Stem Length	4'	6'	8'	10'	12'
Weight	1550	1800	2100	2350	2600
** Stem Length	14'	16'	18'	20'	
Weight	2900	3150	3400	3650	

The face of each T-Wall unit is 5' wide and 2-6" tall and is available in various styles, including dry stack stone, rough hewn masonry blocks, and plain face, as shown.

INDUSTRIAL PRODUCTS

Delivery is available, standard charges apply.